

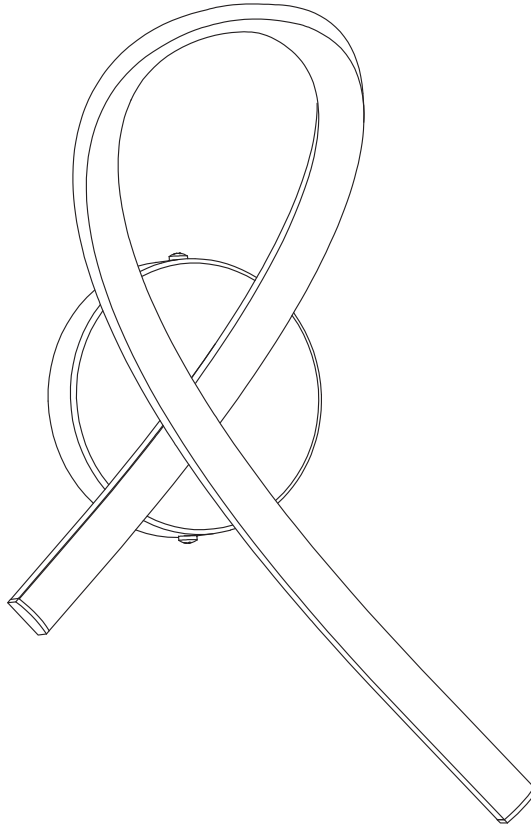







DECOR BUTTERFLY WALL

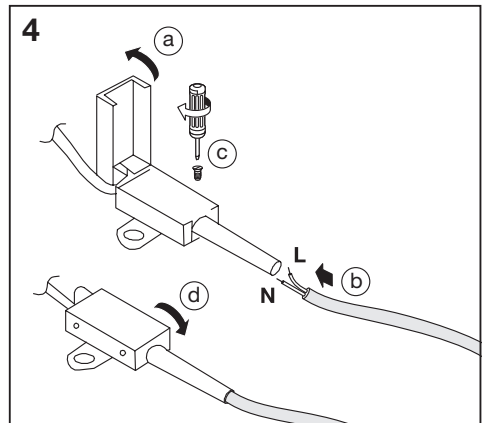
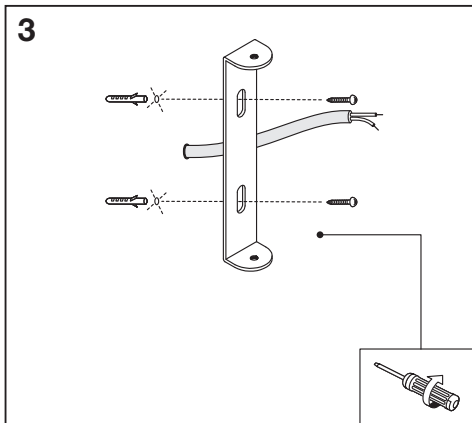
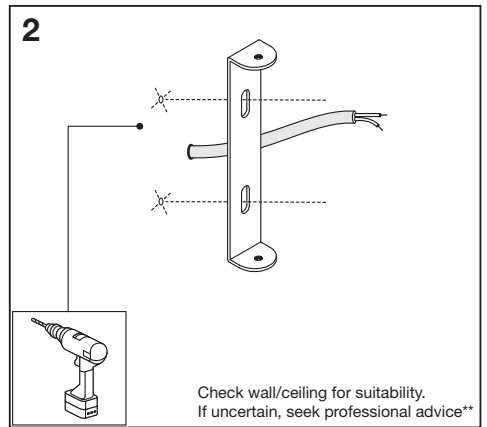
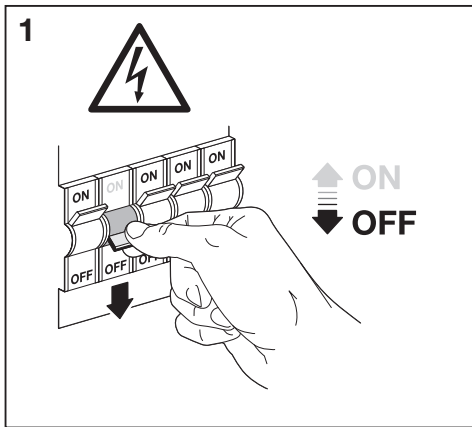
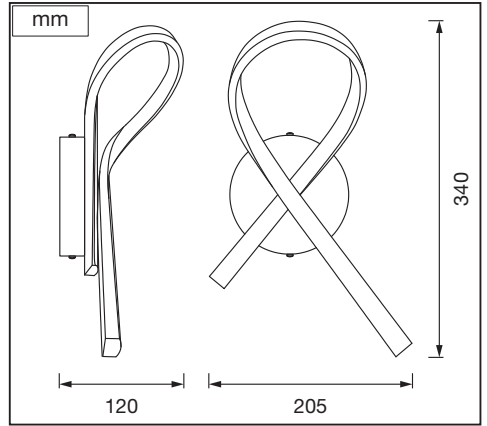
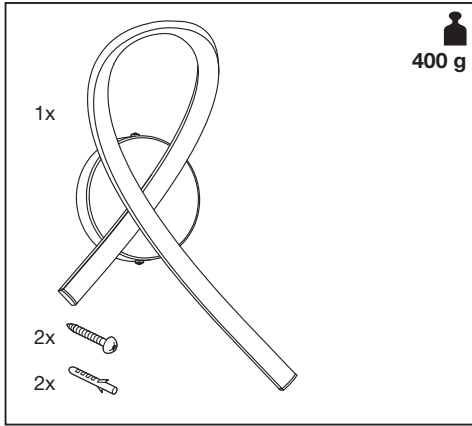
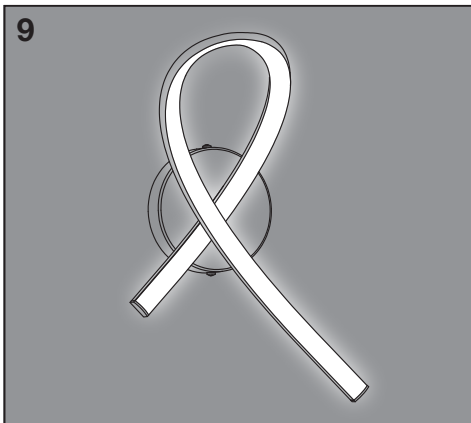
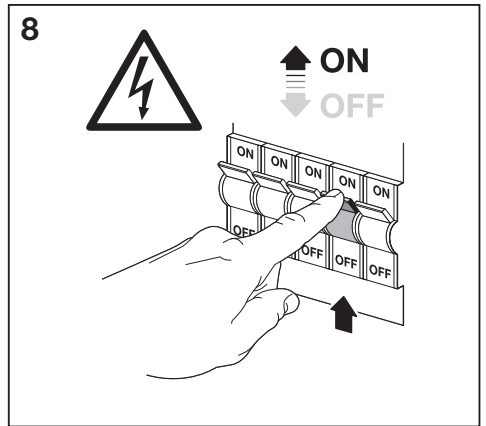
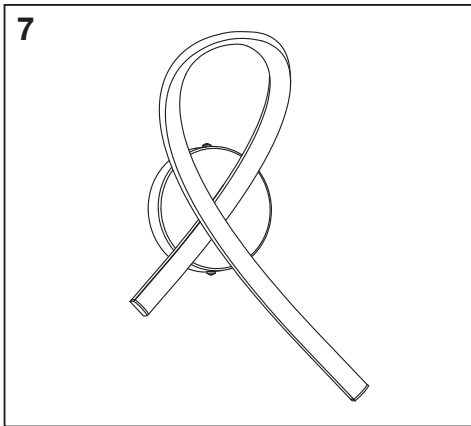
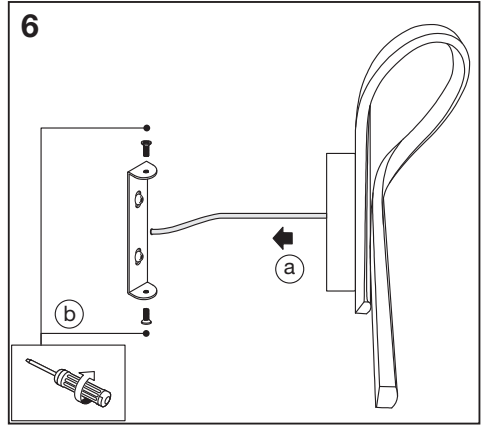
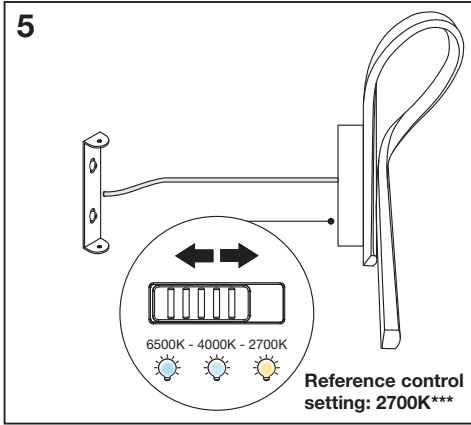







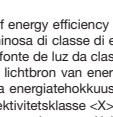
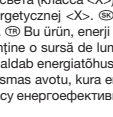















































	EAN	W	lm light source	lm output	K	°(°C)	V~	mA	Hz	DF	PF	▽ (°)	
DECOR BUTTERFLY WALL 12W CCT SI	4058075856707	12	1450 @4000K	750 @4000K	2700/4000/6500	-20...+40	220-240	100	50/60	>0.7	>0.5	124	12500
DECOR BUTTERFLY WALL 12W CCT WT	4058075856721	12	1450 @4000K	900 @4000K	2700/4000/6500	-20...+40	220-240	100	50/60	>0.7	>0.5	124	12500





























						 * X =
DECOR BUTTERFLY WALL 12W CCT SI	4058075856707	8	AC85407			F
DECOR BUTTERFLY WALL 12W CCT WT	4058075856721	8	AC85407			F

*  Dieses Produkt enthält eine Lichtquelle der Energieeffizienzklasse <X>.  This product contains a light source of energy efficiency class <X>.  Ce produit contient une source lumineuse de classe d'efficacité énergétique <X>.  Questo prodotto contiene una sorgente luminosa di classe di efficienza energetica <X>.  Este producto contiene una fuente luminosa de la clase de eficiencia energética <X>.  Este produto contém uma fonte de luz da classe de eficiência energética <X>.  Το προϊόν αυτό περιέχει φωτεινή πηγή της τάξης ενεργειακής απόδοσης <X>.  Dit product bevat een lichtbron van energie-efficiëntieklasse <X>.  Tämä tuote sisältää valonlähteen, jonka energiatehokkuusluokka on <X>.  Dette produktet inneholder en lyskilde med energieffektivitetsklasse <X>.  Dette produkt inneholder en lyskilde i energieffektivitetsklasse <X>.  Tento výrobek obsahuje světelný zdroj s třídou energetické účinnosti <X>.  Та изделек vsebuje svetlobni vir razreda energetske učinkovitosti <X>.  Bu ürün, enerji verimliliği sınıfında bir ışık kaynağı içerir <X>.  Ovaj proizvod sadržava izvor svjetlosti klase energetske učinkovitosti <X>.  Acest produs conține o sursă de lumină cu clasa de eficiență energetică <X>.  Тоzi продукт включва светлинен източник с клас на енергийна ефективност <X>.  Toode sisaldab energiatõhususe klassi <X> valgusallikat.  Šiame gaminyje yra šviesos šaltinis, kurio energijos vartojimo efektyvumo klasė <X>.  Šis s ražojums satur gaismas avotu, kura energoefektivitātes klase ir <X>.  Ovaj proizvod sadrži izvor svetlosti klase energetske efikasnosti <X>.  Цей виріб містить джерело світла класу енергоефективності <X>.  Бул өнімде <X> энергия тиімділігі класының жарық көзі бар.

**  Eignung der Wand/Decke prüfen. Wenn Sie sich nicht sicher sind, lassen Sie sich beraten  Vérifiez l'adéquation du mur/plafond. En cas d'incertitude, demandez conseil à un professionnel  Controllare l'idoneità della parete o del soffitto. In caso di dubbi, consultare un professionista  Compruebe la idoneidad de la pared o techo. Si no está seguro, busque asesoramiento profesional  Verifique a adequação da parede/teto. Se não tiver a certeza, procure aconselhamento profissional  Ελέγξτε τον τοίχο/τον οροφή ως προς την καταλληλότητα. Σε περίπτωση αμφιβολίας, ζητήστε επαγγελματική συμβουλή  Controleer wand/plafond op geschiktheid. Als u niet zeker bent, vraag dan professioneel advies  Kontrollera vägg/tak för lämplighet. Om du är osäker, sök professionell rådgivning  Tarkista seinän/katkon sopivuus. Jos olet epävarma, kysy neuvoa ammattilaiselta  Sjekk om veggens/taket egner seg. Oppsøk profesjonell rådgivning dersom du er usikker  Kontrollør vegg/loft for egnethed. Hvis du er usikker, skal du søge professionel rådgivning  Zkontrolujte vhodnost stěny/stropu. Pokud si nejste jisti, vyhledejte odbornou radu  Проверьте стену/потолок на пригодность. Если у вас есть сомнения, обратитесь за профессиональной консультацией  Ellenőrizze a fal/mennyezet alkalmasságát. Ha bizonytalan, kérjen szakszertű tanácsot  Sprawdź, czy ściana/sufit nadają się do montażu. W razie wątpliwości zasięgnij porady wykwalifikowanej osoby  Skontrolujte vhodnost steny/stropu. Ak si nie ste istí, vyhľadajte odbornú pomoc  Preverite primernost stene/stropa. Če niste prepričani, poiščite nasvet strokovnjaka  Duvarın/tavanını uygun olup olmadığını kontrol edin. Emin değilseniz uzman bir kişiden destek alın  Proverite prikladnost zida/stropa  Nastavenie referenčného ovládnania  Nastavení referenčního ovládnání  Referenčni referenčnega nadzora  Referans kontrolü  Referența kontrola postavka  Setare control de referință  Настройка на референтный контрол  Vārdukontrolis seadistus  Etaloninio valdymo nustatymas  Atsauces vadības iestatījums  Postavka kontrolne referenčne  Налаштування еталонного контролю

***  Referenzkontrollinstellung  Réglage de la commande de référence  Impostazione controllo di riferimento  Configuración de control de referencia  Configuração de controlo de referência  Ρύθμιση χειριζομένου αναφοράς  Referentiesturingsinstelling  Inställning för referenskontroll  Vertikuausetus  Referansekontrollinstilling  Referençekontrolindstilling  Nastavení referenčního ovládnání  Referencia vezérlés beállítás  Ustawienie kontroli wartości odniesienia  Nastavenie referenčného ovládnania  Nastavení referenčního nadzora  Referans kontrolü  Referența kontrola postavka  Setare control de referință  Настройка на референтный контрол  Vārdukontrolis seadistus  Etaloninio valdymo nustatymas  Atsauces vadības iestatījums  Postavka kontrolne referenčne  Налаштування еталонного контролю

RECICLA
Al Azul

22
PAP
Raccolta Carta
Verifica le disposizioni del tuo comune.

FR



FR

Cet appareil et ses accessoires se recyclent

À DÉPOSER EN MAGASIN **À DÉPOSER EN DÉCHÈTERIE**

 **OU** 

Points de collecte sur www.quefairedemesdechets.fr



LEDVANCE SASU
CQM, 5 rue d'Altorf
67120 Molsheim France
www.ledvance.com

LEDVANCE Ltd, Sterling House,
810 Mandarin Court, Warrington,
Cheshire, WA1 1GG, United Kingdom

G11252144
03.12.2025