

ALKALINE-MANGANESE DIOXIDE BATTERY



Size: AA – PC1500

IEC: LR6 | ANSI: 15A

KEY FEATURES

- Reliable Performance
- Resistance to corrosion
- Designed to meet all major quality, safety and environmental standards:
 - Safety: IEC 60086-5
 - ANSI C 18.1M, Part-2
 - EU Battery Directive
 - Quality: ISO 14001 and 9001, Duracell World Class Continuous Improvement Program

TYPICAL APPLICATIONS

- Medical Devices
- Security Cameras
- Soap Dispensers
- Electronic Door Locks
- Window Blinds/Shades

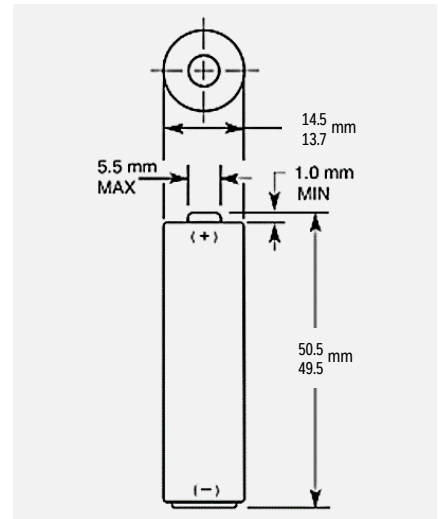

Dimensions shown are ANSI/IEC standards

ELECTRICAL CHARACTERISTICS

- Nominal capacity (25 mA cont., .8V cut-off) 3,075 mAh
- Typical Voltage (at + 20 °C) 1.5 V
- AC Impedance @ 1kHz 80 mΩ

PHYSICAL CHARACTERISTICS

- Typical weight 24 g (0.9 oz)
- Typical volume 8.4 cm³ (0.5 in³)
- Terminals Flat

OPERATING & STORAGE CONDITIONS

- Operating temperature range -20°C to 54°C
(-4°F to 130°F)
- Recommended storage temperature (storage area should be clean, cool, dry and ventilated) 6°C to 29°C
(42°F to 85°F)
- Storage relative humidity 26%-80% RH

Delivered capacity is dependent on the applied load, operating temperature and cut-off voltage. Please refer to the charts and discharge data shown for examples of the energy/service life that the battery will provide for various load conditions.

This data is subject to change. Performance information is typical. Contact Duracell for the latest information.

TYPICAL PERFORMANCE

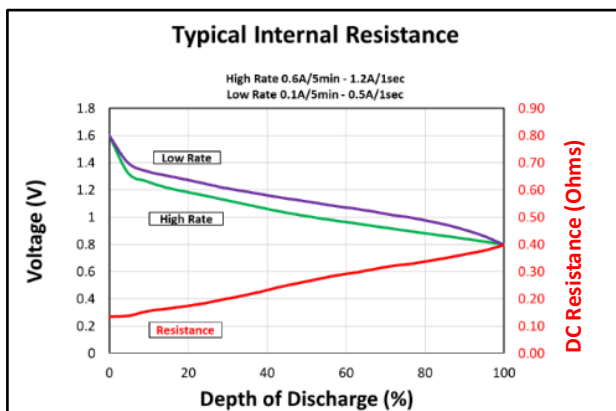
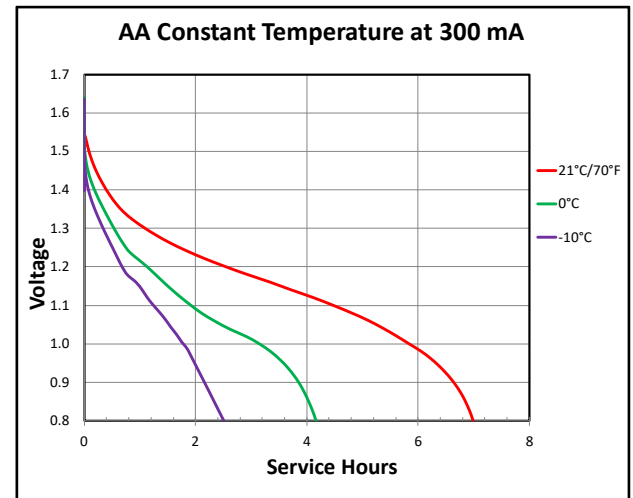
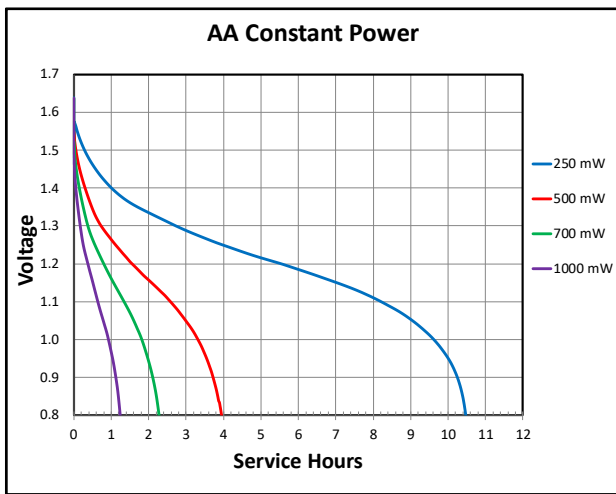
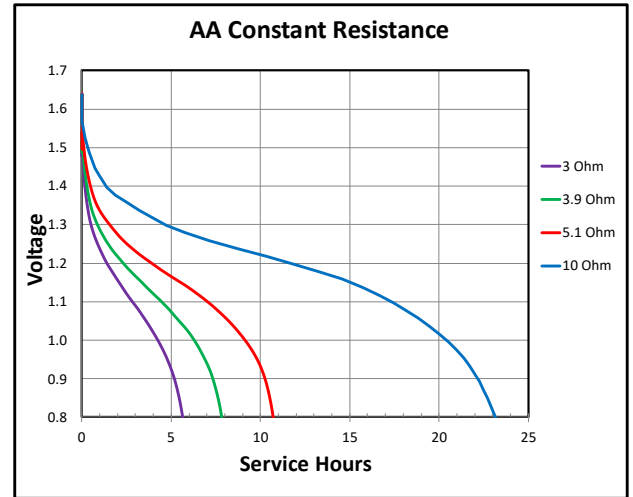
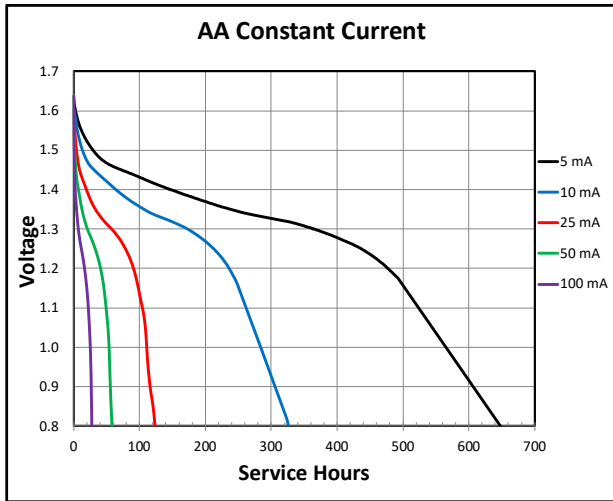

Delivered capacity is dependent on the applied load, operating temperature and cut-off voltage. Please refer to the charts and discharge data shown for examples of the energy/service life that the battery will provide for various load conditions.

This data is subject to change. Performance information is typical. Contact Duracell for the latest information.