

FLOODLIGHT VITAL SENSOR

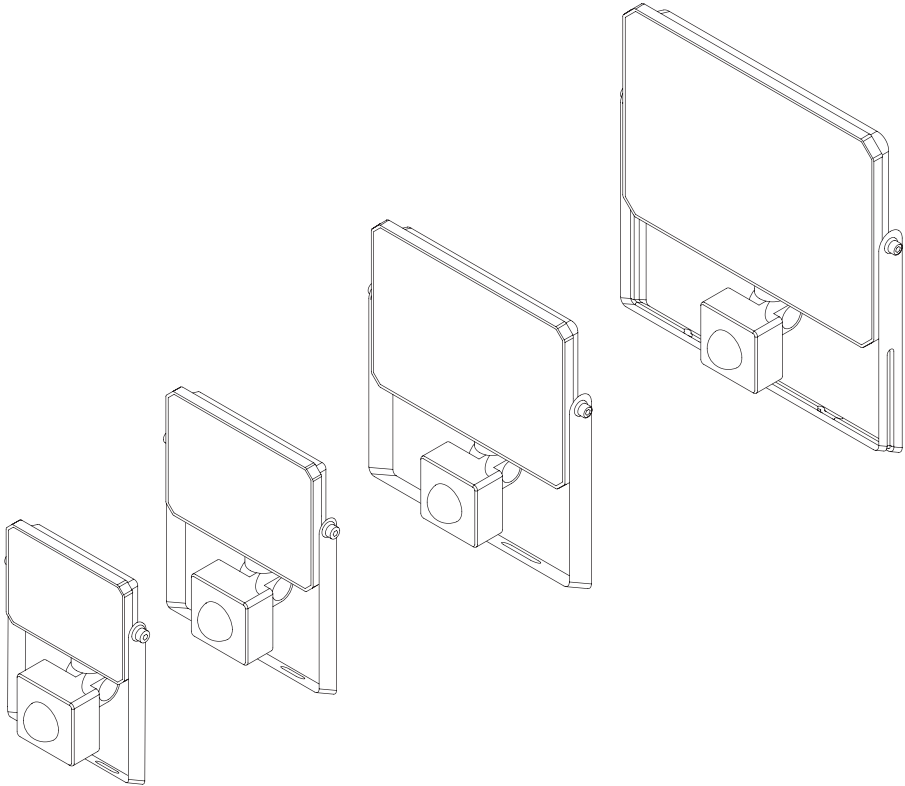

	EAN	l x w x h [mm]	W	V _~	mA	Hz	lm	lm/W	K
FL VITAL SENSOR 10W 830 IP65 BK	4099854493812	102x134x52	10	220-240	52	50	900	90	3000
FL VITAL SENSOR 10W 840 IP65 BK	4099854493836	102x134x52	10	220-240	52	50	900	90	4000
FL VITAL SENSOR 10W 865 IP65 BK	4099854493874	102x134x52	10	220-240	52	50	900	90	6500
FL VITAL SENSOR 20W 830 IP65 BK	4099854493911	124x151x52	20	220-240	88	50	1800	90	3000
FL VITAL SENSOR 20W 840 IP65 BK	4099854493935	124x151x52	20	220-240	88	50	1800	90	4000
FL VITAL SENSOR 20W 865 IP65 BK	4099854493973	124x151x52	20	220-240	88	50	1800	90	6500
FL VITAL SENSOR 30W 830 IP65 BK	4099854494017	159x175x52	30	220-240	135	50	2700	90	3000
FL VITAL SENSOR 30W 840 IP65 BK	4099854494055	159x175x52	30	220-240	135	50	2700	90	4000
FL VITAL SENSOR 30W 865 IP65 BK	4099854494093	159x175x52	30	220-240	135	50	2700	90	6500
FL VITAL SENSOR 50W 830 IP65 BK	4099854494116	206x208x54	50	220-240	225	50	4500	90	3000
FL VITAL SENSOR 50W 840 IP65 BK	4099854494130	206x208x54	50	220-240	225	50	4500	90	4000
FL VITAL SENSOR 50W 865 IP65 BK	4099854494154	206x208x54	50	220-240	225	50	4500	90	6500

	EAN	IP	IK	∇ (°)	R _a	⊘ (°C)	⊘	DF	👤	🖨️
FL VITAL SENSOR 10W 830 IP65 BK	4099854493812	65	04	105	>80	-20...+40	-	>0.85	0.190 kg	20000
FL VITAL SENSOR 10W 840 IP65 BK	4099854493836	65	04	105	>80	-20...+40	-	>0.85	0.190 kg	20000
FL VITAL SENSOR 10W 865 IP65 BK	4099854493874	65	04	105	>80	-20...+40	-	>0.85	0.190 kg	20000
FL VITAL SENSOR 20W 830 IP65 BK	4099854493911	65	04	105	>80	-20...+40	-	>0.90	0.248 kg	20000
FL VITAL SENSOR 20W 840 IP65 BK	4099854493935	65	04	105	>80	-20...+40	-	>0.90	0.248 kg	20000
FL VITAL SENSOR 20W 865 IP65 BK	4099854493973	65	04	105	>80	-20...+40	-	>0.90	0.248 kg	20000
FL VITAL SENSOR 30W 830 IP65 BK	4099854494017	65	04	105	>80	-20...+40	-	>0.90	0.394 kg	20000
FL VITAL SENSOR 30W 840 IP65 BK	4099854494055	65	04	105	>80	-20...+40	-	>0.90	0.394 kg	20000
FL VITAL SENSOR 30W 865 IP65 BK	4099854494093	65	04	105	>80	-20...+40	-	>0.90	0.394 kg	20000
FL VITAL SENSOR 50W 830 IP65 BK	4099854494116	65	04	105	>80	-20...+40	-	>0.90	0.595 kg	20000
FL VITAL SENSOR 50W 840 IP65 BK	4099854494130	65	04	105	>80	-20...+40	-	>0.90	0.595 kg	20000
FL VITAL SENSOR 50W 865 IP65 BK	4099854494154	65	04	105	>80	-20...+40	-	>0.90	0.595 kg	20000

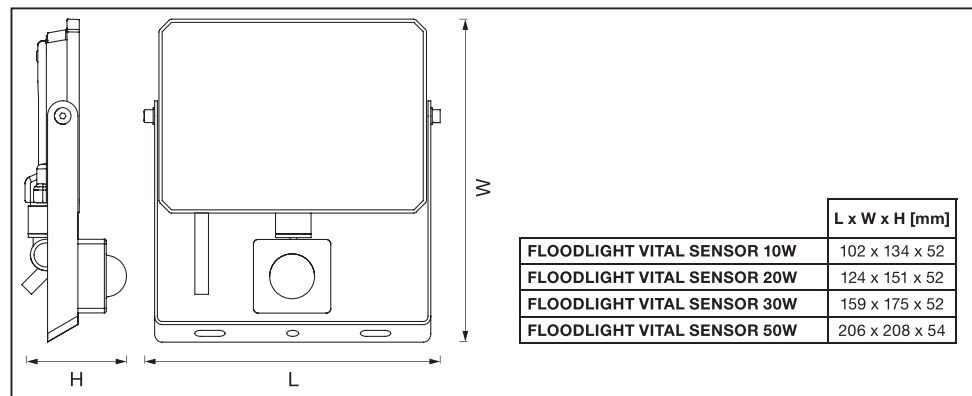
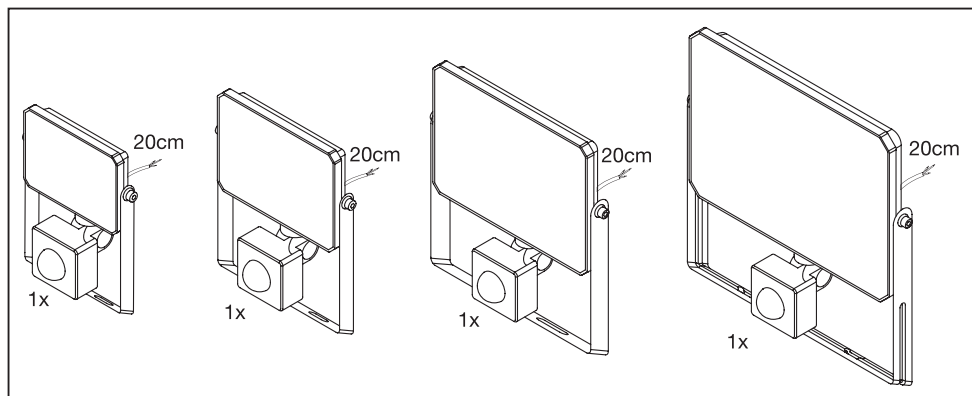

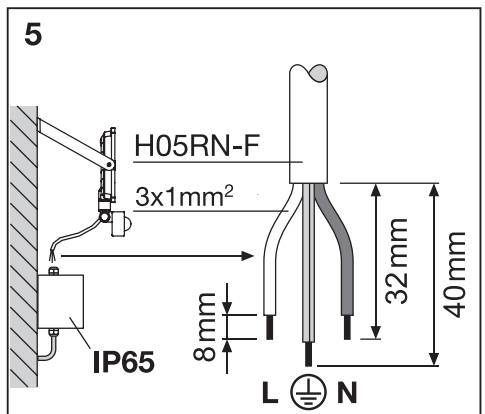
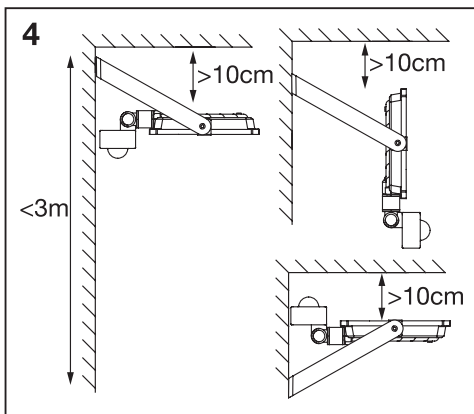
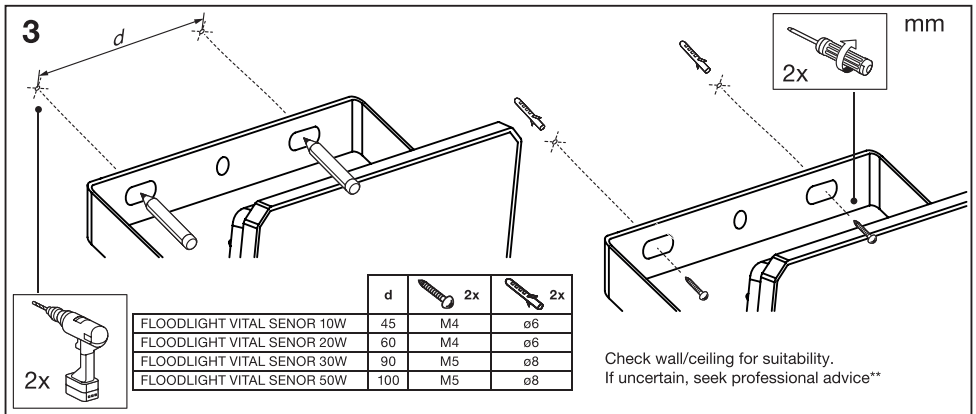
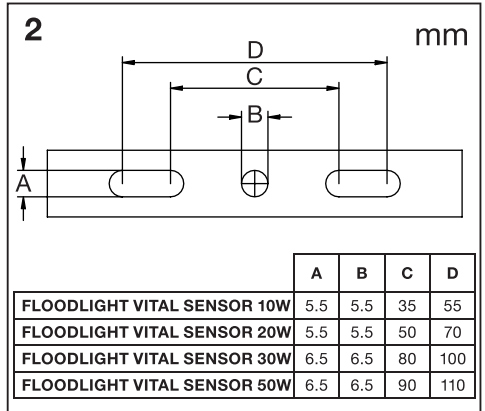
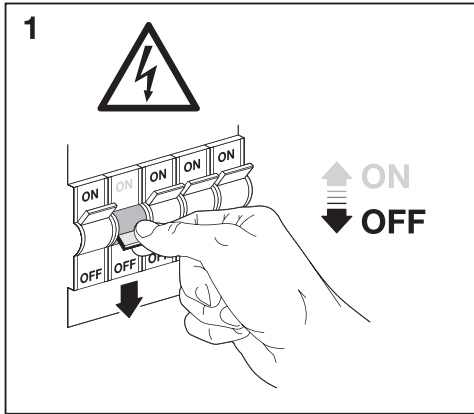

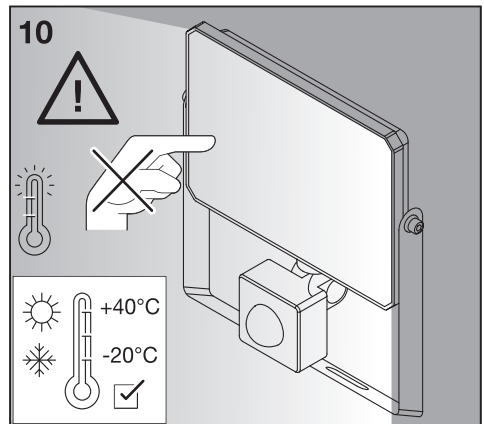
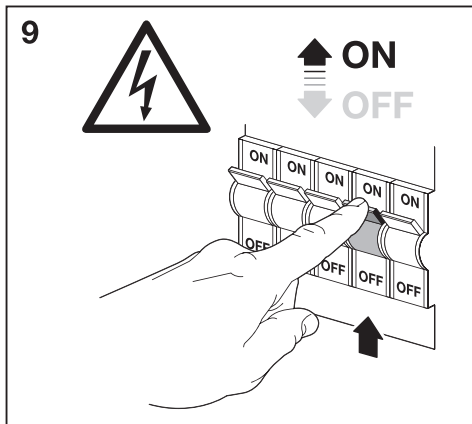
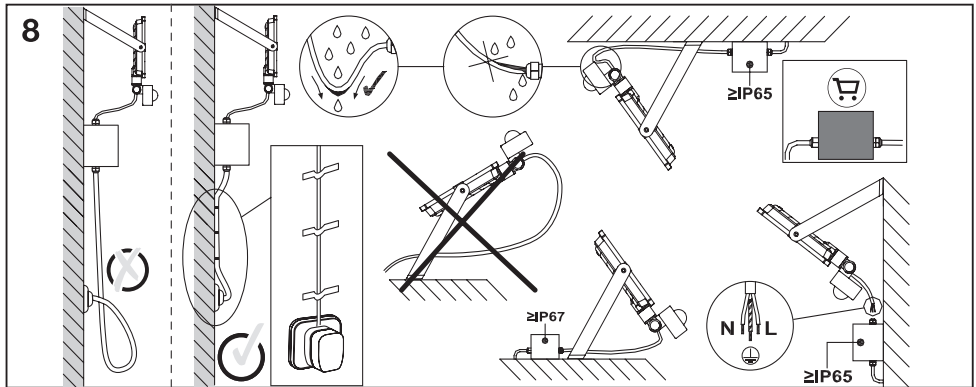
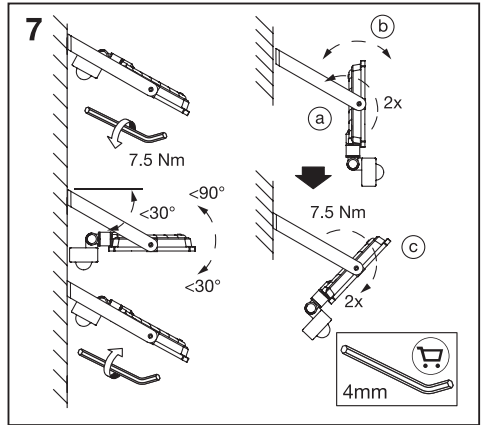
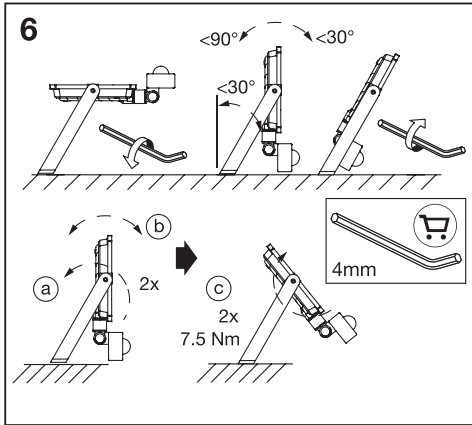

**	C-10A	B-16A	C-16A
FLOODLIGHT VITAL SENSOR 10W	134	164	215
FLOODLIGHT VITAL SENSOR 20W	90	145	145
FLOODLIGHT VITAL SENSOR 30W	59	94	94
FLOODLIGHT VITAL SENSOR 50W	35	56	56

** Ⓢ Eignung der Wand/Decke prüfen. Wenn Sie sich nicht sicher sind, lassen Sie sich beraten. Ⓢ Vérifiez l'adéquation du mur/plafond. En cas d'incertitude, demandez conseil à un professionnel. Ⓢ Controllare l'idoneità della parete o del soffitto. In caso di dubbi, consultare un professionista. Ⓢ Compruebe la idoneidad de la pared o techo. Si no está seguro, busque asesoramiento profesional. Ⓢ Verifique a adequação da parede/teto. Se não tiver a certeza, procure aconselhamento profissional. Ⓢ Ελέγξτε τον τοίχο/την οροφή ως προς την καταλληλότητα. Σε περίπτωση αμφιβολίας, ζητήστε επαγγελματική συμβουλή. Ⓢ Controleer wand/plafond op geschiktheid. Als u niet zeker bent, vraag dan professioneel advies. Ⓢ Kontrollera vägg/tak för lämplighet. Om du är osäker, sök professionell rådgivning. Ⓢ Tarkista seinän/katon sopivuus. Jos olet epävarma, kysy neuvoa ammattilaiselta. Ⓢ Sjekk om veggen/taket egner seg. Oppsøk professionell rådgivning dersom du er usikker. Ⓢ Kontroller væg/toft for egnethed. Hvis du er usikker, skal du søge professionel rådgivning. Ⓢ Zkontrolujte vhodnost stěny/stropu. Pokud si nejste jisti, vyhledejte odbornou radu. Ⓢ Проверьте стену/потолок на пригодность. Если у вас есть сомнения, обратитесь за профессиональной консультацией. Ⓢ Ellenőrizze a fal/mennyezet alkalmasságát. Ha bizonytalan, kérjen szaksterű tanácsot. Ⓢ Sprawdź, czy ściana/sufit nadają się do montażu. W razie wątpliwości zasięgnij porady wykwalifikowanej osoby. Ⓢ Zkontrolujte vhodnost steny/stropu. Ak si nie ste istí, vyhľadajte odbornú pomoc. Ⓢ Preverite primernost stene/stropa. Če niste prepričani, poiščite nasvet strokovnjaka. Ⓢ Duvanni/tavanini uygun olup olmadığını kontrol edin. Emin değilseniz uzman bir kişiden destek alın. Ⓢ Proverite prikladnost zida/stropa. Ako niste sigurni, potražite stručni savjet. Ⓢ Verificați dacă perețele/tavanul este adecvat. În caz de incertitudine, solicitați consultanță de specialitate. Ⓢ Проверете пригодността на стената/тавана. Ако не сте сигурни, потърсете професионален съвет. Ⓢ Kontrolli seinale/lakke sobivust. Kahtluse korral küsi professionaalilt nõu. Ⓢ Patkinkite sienos/lubu tinkamumą. Jei kyla abejonų, kreipkitės į specialistą. Ⓢ Pārbaudiet sienu/griestu piemērotību. Neskaidrību gadījumā meklējiet profesionālu palomu. Ⓢ Proverite pogodnost zida/plafona. Ako niste sigurni, potražite stručni savet. Ⓢ Переверіть відповідність стіни/стелі. Якщо ви не впевнені, зверніться за професійною консультацією. Ⓢ Қабырғаның/төбесінің жарамдылығын тексеріңіз. Егер сенімді болмасаңыз, кәсіби кеңеске жүгініңіз.



Points de collecte sur www.quefairedemesdechets.fr

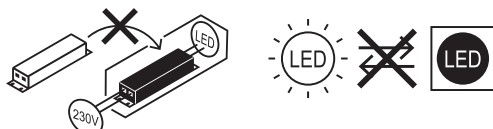

LEDVANCE SASU
CQM, 5 rue d'Altorf
67120 Molsheim France
www.ledvance.com

Ⓢ LEDVANCE Ltd, Sterling House, 810
Mandarin Court, Warrington, Cheshire,
WA1 1GG, United Kingdom

C10449057
G11218486v1
11.02.25